

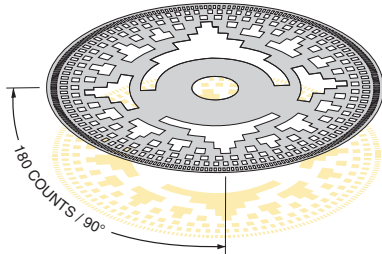

## Spectrum DT Position Transmitter



Westlock™ has merged absolute encoder sensing technology with loop-powered analog transmission to create the Spectrum DT full-range position monitor. The communication mode continues to be the standard 4-20 mA analog signal while actual sensing is achieved by a true digital sensor.

### Key Performance Benefits

- Reference accuracy is three times that of traditional analog sensors.
- Shifts due to environmental effects such as temperature are improved by a factor of three or more compared with traditional analog sensors.
- Greater repeatability and accuracy that digital control systems brought to the control room have now been extended into process measurement in the field.
- Non-contact means of position sensing yields higher accuracy over the life of the product.

### True Digital Position Sensing

An absolute encoder is a position verification device which provides position information for each shaft location. The digital code is unique to each location. In absolute encoders, there are several concentric tracks, each with an independent light source. As light passes through a slot, a high state called “true 1” is created. When light does not pass, a low state known as “false 0” is created. Shaft position is identified by the pattern of 1’s and 0’s.

### Loop-Powered 4-20 mA Transmission

The 4-20 mA analog signal, which has long been a useful method of interfacing sensors to remote computers, is the main standard for data transmission of the Spectrum DT.

The Spectrum DT Position Transmitter derives its operating power from the 4-20 mA loop itself, with no need for an external power connection. This is a high-level signal not easily affected by outside noise. In addition to the advantages of standardization, reduced field wiring costs and immunity from most electrical noise, the 4-20 mA transmitter offers these benefits:

- Any number of signal receivers can be series-connected into the signal circuit without upsetting calibration.
- Multiple transmitters may share the same power supply.
- A 4-20 mA signal is a “live zero” signal, which distinguishes a process condition (4 mA) from an open circuit condition (0 mA).
- No position loss on power down.
- Operates in electrically noisy environments.

### Power Supply Requirements

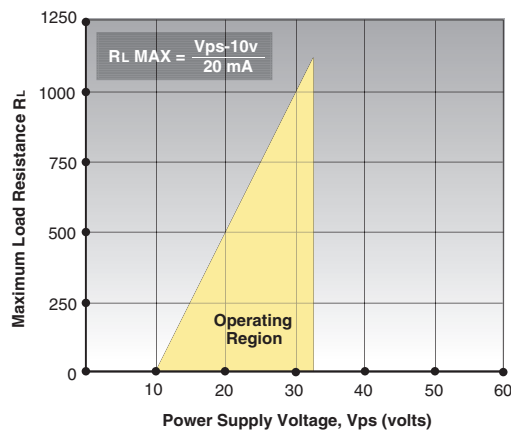

## Technical Specifications

Transmitter type	Angular position, intended primarily for control valve applications, damper applications, and similar uses
Output	4 to 20 milliamperes (2 wire), proportional to position. Position range is 90° (reversible) corresponding to nominal output current range
Operating principle	Absolute shaft encoder, non-contacting
Electrical overrange capability	90° of span under range of 4° and over range of 15°. For travel below range bottom, output current will limit at minimum of approximately 3.2 mA
Mechanical overrange capability	Infinite (shaft may be continuously rotated)
End of range wraparound	Provided 180° away from range midpoint
Terminal voltage required	10 to 32 volts DC. Reverse polarity protected
Temperature range	[-32°C to +85°C] Sunshade available for use when needed
Temperature effect	Less than [0.16%/°C] referred to full scale
Humidity range	10% to 90%, non-condensing
Terminal voltage effect	Less than 0.1%, from 10 to 32 volts
Linearity	Within 0.5 least significant bit
Output update rate	Once per second
Startup stabilization time	6 seconds, nominal
Resolution	0.7° 256 counts in 180°

### Spectrum 4-20 mA Transmitter with 2 SPDT Magnum Sensors and 10 Point Terminal Strip

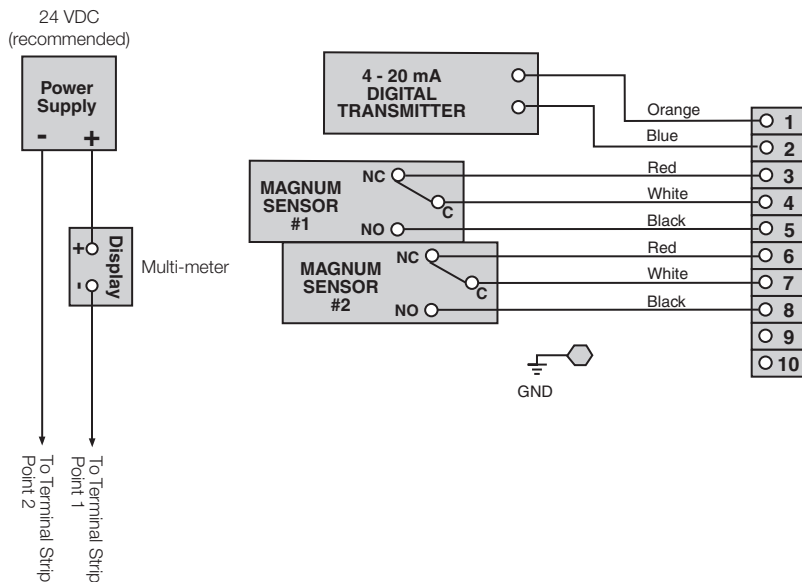

**Note:** There is no required polarity for the 2 wire 4-20 mA wiring of the transmitter.

**USA/Canada:** Saddle Brook, NJ  
Ph: 201-794-7650  
Dedicated Order Fax: 201-794-4790  
General Fax: 201-794-0913  
[www.westlockcontrols.com](http://www.westlockcontrols.com)

**Europe/Asia:** Kent, England  
Ph: + 44 189 251 6277  
Fax: + 44 189 251 6279  
[www.westlockuk.com](http://www.westlockuk.com)

**South America:** Barueri, Sao Paulo  
Ph: + 55 11 2588 1400  
Fax: + 55 11 2588 1410  
[www.westlock.com.br](http://www.westlock.com.br)

Tyco Flow Control (TFC) provides the information herein in good faith but makes no representation as to its comprehensiveness or accuracy. This data sheet is intended only as a guide to TFC products and services. Individuals using this data sheet must exercise their independent judgment in evaluating product selection and determining product appropriateness for their particular purpose and system requirements. TFC MAKES NO REPRESENTATIONS OR WARRANTIES, EITHER EXPRESS OR IMPLIED, INCLUDING WITHOUT LIMITATION ANY WARRANTIES OF MERCHANTABILITY OR FITNESS FOR A PARTICULAR PURPOSE WITH RESPECT TO THE INFORMATION SET FORTH HEREIN OR THE PRODUCT(S) TO WHICH THE INFORMATION REFERS. ACCORDINGLY, TFC WILL NOT BE RESPONSIBLE FOR DAMAGES (OF ANY KIND OR NATURE, INCLUDING INCIDENTAL, DIRECT, INDIRECT, OR CONSEQUENTIAL DAMAGES) RESULTING FROM THE USE OF OR RELIANCE UPON THIS INFORMATION. Patents and Patents Pending in the U.S. and foreign countries. Tyco reserves the right to change product designs and specifications without notice. All registered trademarks are the property of their respective owners. Printed in the USA.